



TECHNICAL INFORMATION

Bulletin

NUMBER TWO

Horizontal vs. Vertical Pumps

An engineering analysis of a controversial issue, considering these key points:

- space requirements
- NPSH, priming, flexibility
- Corrosion, maintenance

Melvin S. Mann, Peerless Pump Company

IN MANY PUMP applications the question "should a horizontal or vertical pump be used" deserves careful study. Frequently the type of pump is dictated by the installation and there simply is no choice between the two.

Perhaps the most frequent example of this is the deep well vertical turbine type of pump used extensively for pumping water from deep wells with pump settings as much as 1000 feet below the surface. However, there are many marginal cases where either a horizontal or vertical pump could be used. In such cases it is necessary to appreciate and consider some of the inherent advantages of one type over the other so that a proper choice can be made. It is the purpose of this paper to point out some of the factors which should be considered if there is an opportunity to choose between using a horizontal or vertical type of pump. Because of the widespread use of the vertical turbine unit, this specific type of vertical pump will be used as a basis of comparison with horizontal centrifugal types.

Space Requirements- If available floor area is limited, a vertical unit generally requires less area. However, if available headroom is limited the horizontal unit almost invariably

requires less headroom. Perhaps the best way to indicate space requirements is by typical example. It should be kept in mind that area and height requirements will differ somewhat between various manufacturers and with the type of configuration of the unit specified. Figures 1, 2, and 3, and Table 1 compare actual dimensions of horizontal with vertical pumps.

The comparison of both designs of horizontal pumps with the vertical, expressed as ratios.

(A1/A3, H3/H1 etc.), clearly demonstrates the general order of magnitude of the area and height differences of the three types of pumps. It should be noted that the vertical turbine occupies even less floor area than the close coupled unit shown in Figure 1. In general then, consider the vertical where available area is critical and the horizontal where available headroom is critical.

Priming-Where the level of the liquid to be pumped is below the floor level, no special priming equipment is required for the vertical turbine pump since the impellers are always submerged. However, where a horizontal pump is used, some method must be used to raise the water to the impeller before the pump is started.

This can be accomplished by using auxiliary vacuum pumps, air aspirators, or self priming pumps. Foot valves can also be used so that once filled, the suction pipe is kept full of liquid at all times. However, the point to keep in mind is that the vertical turbine pump is always primed or submerged and thus requires no special priming equipment or special starting procedures.

Net Positive Suction Head-In order to avoid cavitation, the net positive suction head (NPSH) available must be greater than the NPSH required by the pump. For a given set of conditions the NPSH available increases as the submergence over the pump increases or if there is a suction hit, the NPSH available increases as the lift is decreased. On vertical pumps, as noted in the discussion above on priming, the suction lift is eliminated and, furthermore, it usually is a comparatively simple matter to provide enough submergence by properly selecting the length of vertical column and thus provide enough NPSH available to simplify the pump selection "cavitation-wise." In contrast to this, a given a given horizontal pump has no flexibility since the amount of suction

Continued on page 2

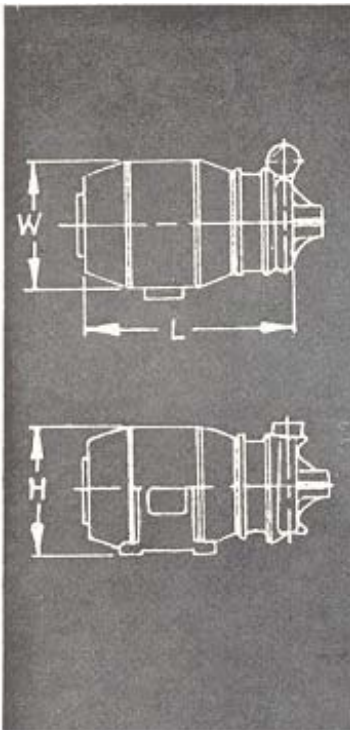

Figure 1. HORIZONTAL close coupled end suction.

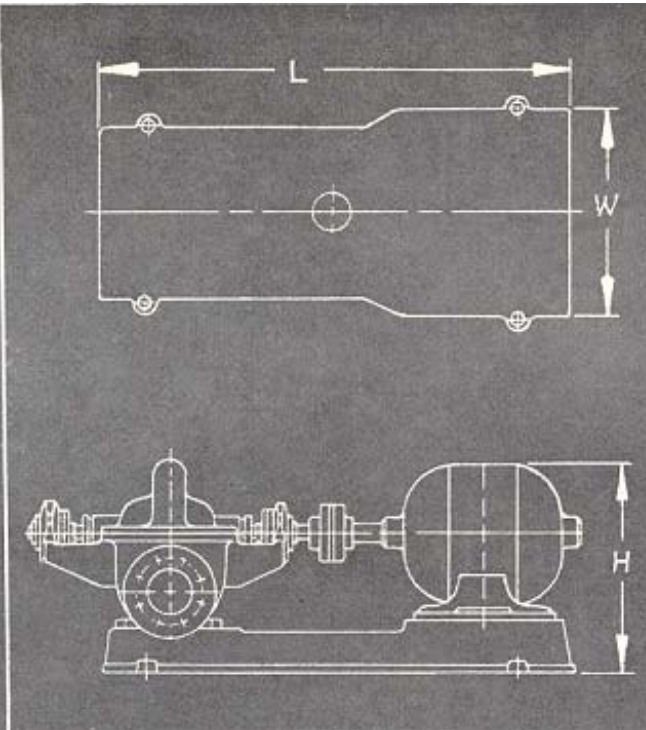

Figure 2. HORIZONTAL double suction split case.

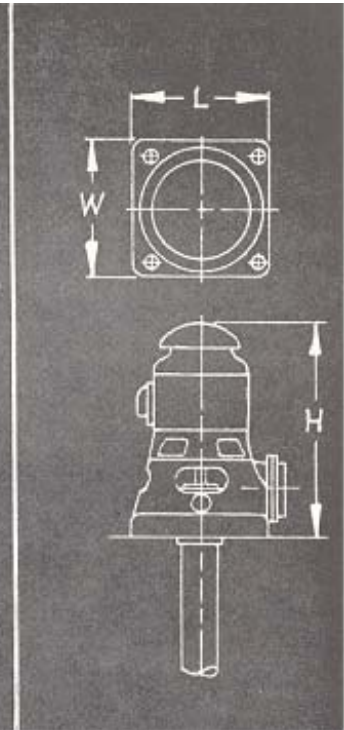

Figure 3. VERTICAL turbine pump

GPM	Head, Ft.	Motor Hp	Motor Speed	Fig. 1. HORIZONTAL END SUCTION				Fig. 2. HORIZONTAL DOUBLE SUCTION				Fig. 3. VERTICAL TURBINE				Area Ratio		Height Ratio	
				L	W	A1	H1	L	W	A2	H2	L	W	A3	H3	A/A3	A2/A3	H3/H	H3/H2
100	130	5	3460	25.50	11.00	281	8.75	41.50	16.50	685	17.88	12.50	12.50	156	27.38	1.8	4.4	3.1	1.5
150	250	15	3460	31.38	15.88	497	8.69	46.12	20.00	922	19.00	19.00	19.00	361	36.19	1.4	2.6	4.2	1.9
300	200	20	3460	35.50	15.88	564	12.88	51.44	21.00	1080	21.00	19.00	19.00	361	42.44	1.6	3.0	3.3	2.0
500	160	25	3460	36.75	16.50	606	13.88	51.44	21.00	1080	21.00	21.00	21.00	441	42.44	1.4	2.5	3.1	2.0
1000	160	50	1760					67.12	29.00	1945	28.50	21.00	21.00	441	50.62		4.4		1.8
1500	160	75	1760					67.12	29.00	1945	31.00	23.00	23.00	529	57.75		3.7		1.9
2000	160	100	1760					81.25	35.25	2860	33.33	31.00	31.00	961	65.75		3.0		2.0
2500	190	150	1760					81.25	35.25	2860	34.88	31.00	31.00	961	72.50		3.0		2.1
3000	210	200	1760					98.50	43.50	4280	38.62	31.00	31.00	961	72.50		4.5		1.9
3500	225	250	1760					97.00	44.00	4275	43.00	38.00	38.00	1444	77.25		3.0		1.8

NOTE: L, W, & H are expressed in inches.

H = Over-all Height.

A = Total Floor Area of Base Expressed in square inches

Horizontal vs. Vertical Pumps

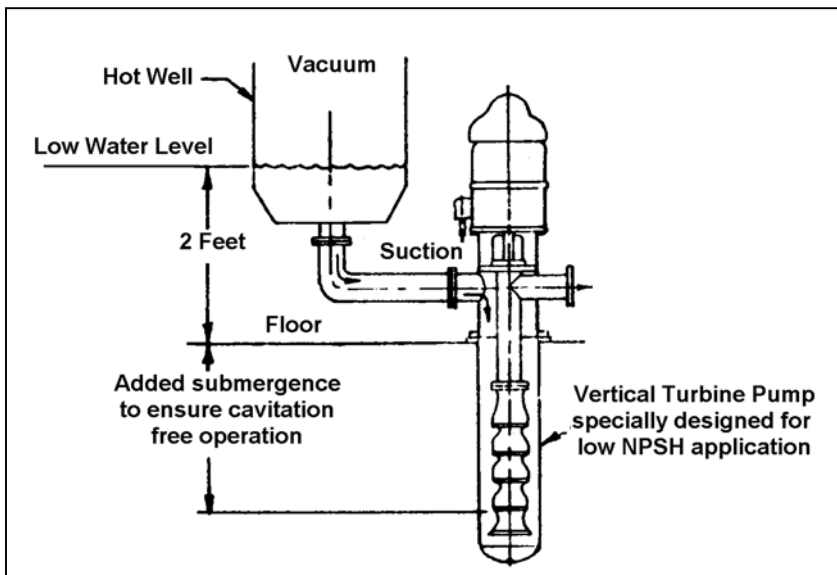

lift or submergence is fixed by the plant layout. Consequently where extremely low NPSH is available the vertical pump is usually far easier to adapt than a horizontal.

A good example of this occurs frequently in the application of condensate pumps. Hot wells are often located close to the floor in order to reduce the over-all height and thus the cost of the building. However, by so doing, the NPSH available with respect to the floor is minimized. Thus it is not uncommon on condensate pump applications to have only 2 or 3 feet NPSH available with respect to the floor. It can be seen from Figure 4 that by using a vertical pump enough submergence can be added to the 2 or 3 feet to insure cavitation-free operation.

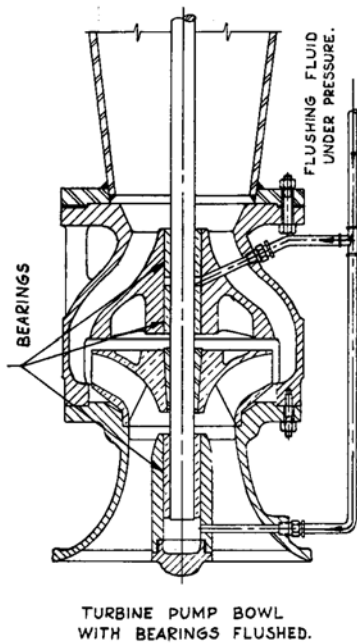

Figure 5. Vertical Pump bowl designed for use of special flushing fluid.

In addition to the example just discussed, other common applications occur where NPSH is critical such as pumping highly volatile fluids (propane, ammonia, etc.). Also, there are installations where hydraulic losses in the suction pipe leading to the pump are sufficiently high to reduce the absolute pressure of the fluid to a point where it is one or two pounds over the vapor pressure, thus normally requiring a vertical to increase the submergence of NPSH available.

Flexibility-Where changes in pumping heads are anticipated because of plant expansion, changes in a process, or transfer of the pump to a different service, it is relatively easy and inexpensive to add or remove stages from a vertical turbine type pump in order to meet the new conditions. Many users recognize the limitation of the horizontal type of pump in this respect and partially compensate for this shortcoming by specifying on new equipment that full diameter and minimum diameter impellers are not acceptable. It should be recognized that this practice can sometimes mean that the manufacturer, to avoid Using a full diameter impeller, is forced to select a pump larger than necessary to meet the initial conditions and in some cases less efficient pump.

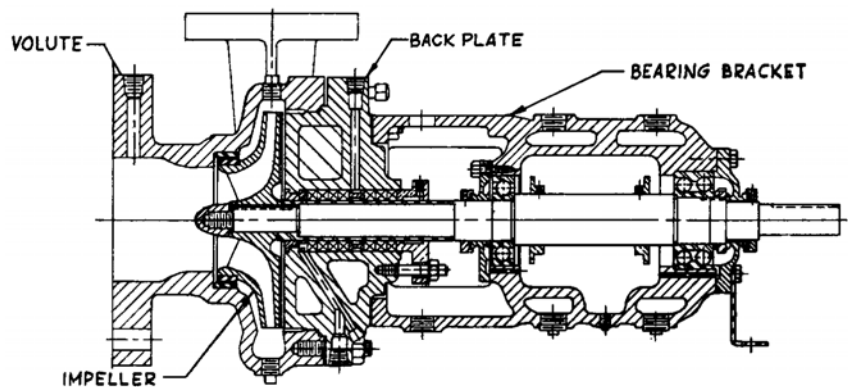

Figure 6. Typical horizontal process pump.

Thus, both initial and operating costs are increased in some cases, in order to have a unit which is capable of an increase in head by substituting a full or larger diameter impeller, if and when the need arises. Vertical turbine pumps, however, can be staged and de-staged relatively easily. Where increased heads are anticipated, the vertical turbine can be built so that additional stages can be added in the future, often with little expense compared with the initial cost of the unit. This usually means furnishing the pump initially with sufficiently large shafting and motor base to accommodate the increased future horsepower. Where the head is decreased, it is a simple matter to de-stage the bowl unit.

Corrosion and Abrasion - The high cost of repair and down time on many pumps which are applied on corrosive and/or abrasive applications is well known to operating personnel. On vertical turbine pumps the bearings are lubricated by the fluid being pumped. This is a distinct disadvantage when compared with horizontal centrifugal units where the pump bearings are usually if not always oil or grease lubricated and are completely isolated from the fluid being pumped.

It is true that vertical turbine process pumps have been successfully applied for corrosive fluids by using special bearing materials such as TFE, graphitar, boron carbide, Babbitt and meehanite. It is also true that in severe abrasive service the bearings can be flushed by a clean non-corrosive fluid provided the process fluid will not be contaminated by the flushing fluid. Such a design is shown in Figure 5. However, use of special bearing lubrication

or materials means special non-standard equipment with relatively high initial costs and longer delivery. Therefore, where other considerations are equal, the horizontal pump "bearing-wise" has a distinct advantage over the vertical turbine where severe abrasion and/or corrosion is to be expected.

Figure 6 pictures a horizontal-type process pump. Note the entire bearing bracket is isolated from the fluid being pumped by means of the backplate. This type of design means that only the shaft, volute, impeller and backplate need be made of corrosion bracket usually made of inexpensive material such as cast iron. In contrast to this, all parts of the vertical turbine are exposed to the fluid and consequently must be made of suitable material throughout in order to resist corrosive attack. Thus, in addition to the bearing problem, a vertical turbine process pump made out of high alloy materials is considerably more expensive than a horizontal process pump made with the same high alloy and designed for the same service.

Inspection and Repair - In general, the horizontal pump is far more accessible for inspection, maintenance and repair than the vertical turbine pump. There are undoubtedly exceptions to this, plus the fact that ease of maintenance of various types of horizontals will vary considerably. However, to inspect a turbine pump bowl the motor, motor base, and column all must be removed before the bowl can be disconnected from the

(continued on page 4)

Horizontal vs. Vertical Pumps

column to which it is attached. In contrast to this, for example, is the double suction, horizontally split, horizontal pump. Figure 7 pictures such a pump. With the upper half of the case removed thus allowing the complete rotating unit to be visually inspected and removed if necessary. Neither the piping nor the motor need be disturbed to remove the rotating element. There are also vertically split horizontal pumps designed so that it is unnecessary to disturb the motor or piping in order to remove the rotating assembly.

Conclusions- Besides the characteristics of the pump itself, there are certainly other factors which influence the choice of pumping equipment, not the least of which is the design and configuration of the plant equipment and layout, with which the pump must be coordinated. Other factors such as safety regulations will affect the choice of pumping equipment. For example, in order to avoid side outlets in the storage tank it is normally good safety practice on above ground tanks to use vertical wet pit pumps when pumping oleum.

But even where well defined factors such as these do not pre-determine the choice of pump types, it is a mistake to make any hard and fast rules about the selection of a horizontal over a vertical or vice versa. Often in marginal cases, where new equipment is being considered, it would be expedient to obtain quotations on both horizontal and vertical types. Each application must be judged on its won merits, keeping in mind the basic advantages and disadvantages of each type, as outlined above.

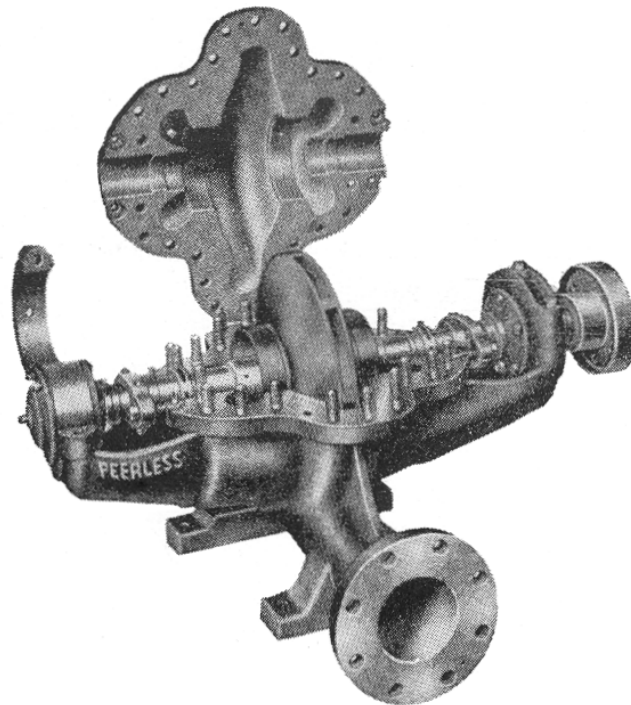

View of double-suction, horizontally split, horizontal pump

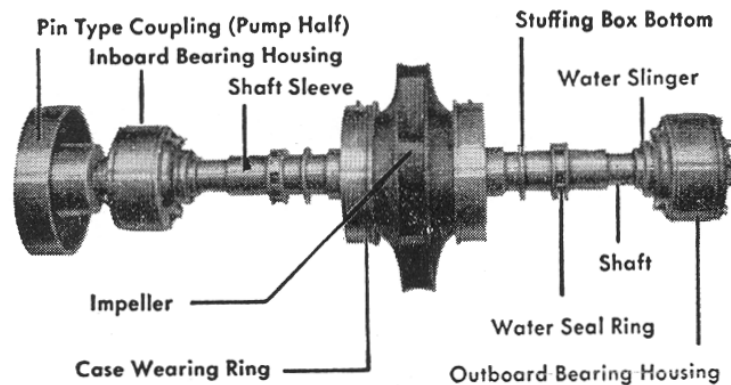

Figure 7